

Promat PROMASEAL® Fire Compound

APPLICATIONS

Promat PROMASEAL® Fire Compound is used to provide a fire seal around service penetrations in walls and floors. The formless nature of the fire compound prior to setting allows it to be introduced between services and so create a complete void free seal, including around bunches of cables. Promat PROMASEAL® Fire Compound is also ideal for use around pipes and ducts where these penetrate compartment or separating walls or floors. Even when fully cured Promat PROMASEAL® Fire Compound permits the provision of additional or replacement services without the need to replace the complete installation, yet still retaining its strength properties. Acoustic data is available on this product, please contact the Promat Technical Services Department on +971 (4) 232 9780.

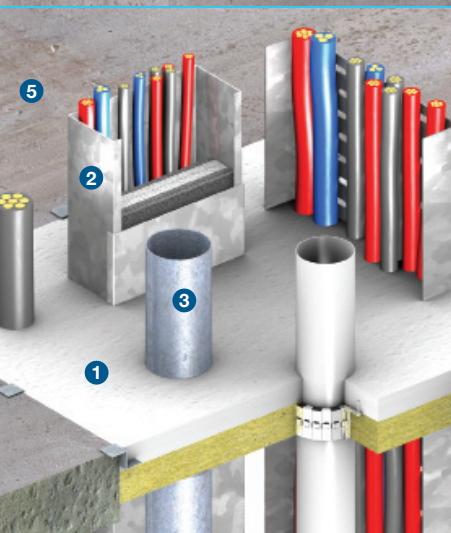
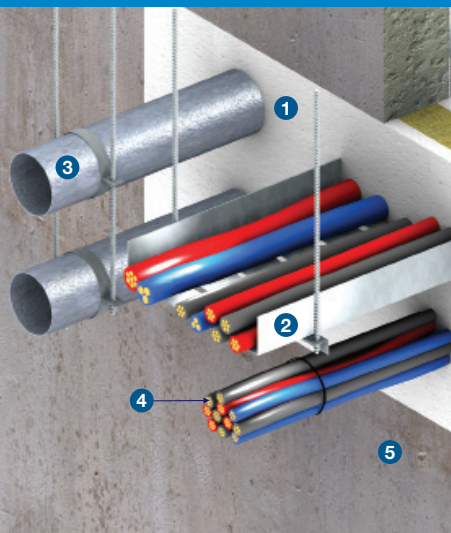

INTRODUCTION

Promat PROMASEAL® Fire Compound is a white powder, which is mixed with water to the required consistency for installation.

When set, Promat PROMASEAL® Fire Compound becomes a hard material with a white matt finish. The actual surface finish of the set product is dependent upon treatment at the time of application.

FIRE PERFORMANCE

The fire performance of Promat PROMASEAL® Fire Compound will depend upon the thickness of the finished seal. Promat PROMASEAL® Fire Compound has been tested to the procedures and adopting the criteria of BS 476: Part 20: 1987 for up to 240 minutes.

ADVANTAGES of Promat PROMASEAL® Fire Compound

- Fire tested for up to 240 minutes
- Easy to apply
- Proven method
- Compatible with all known building products
- Gas tight seal

INSTALLATION

General

Promat PROMASEAL® Fire Compound is mixed with water to the required consistency. The powder should always be added to the water to ensure complete wetting. As a guide, in wall applications a stiffer mix is required, thus it is suggested that a mixing ratio of 2 parts Promat PROMASEAL® Fire Compound to 1 part water (by volume) be used. Where a pouring grade is required it is suggested that the ratio should be 3 parts Promat PROMASEAL® Fire Compound to 2 parts water (by volume).

When movement of the services is expected it is good practice to point around the services with Promat PROMASEAL® Silicone Sealant. After setting, additional penetrations for services can be formed with normal hand tools. Redundant apertures can be readily filled with additional PROMASEAL® Fire Compound.

LOADBEARING SYSTEMS

Temporary foot traffic to maximum of 1.5kN/m² can be applied to Promat PROMASEAL® Fire Compound. Alternatively, use Promat PROMASEAL® Extra Strength Fire Compound. Please contact the Promat Technical Services Department for further information.

TECHNICAL DATA

240 minutes fire rating, integrity in accordance with the criteria of BS 476: Part 20: 1987. Insulation achieved will be dependent upon the building element and type of services.

- | | |
|---|---------------------------------|
| 1 PROMASEAL® Fire Compound :
wall penetration = 100mm.
floor penetration = 100mm. | 3 Metal pipe. |
| 2 Electrical cables and cable tray. | 4 Telecommunication cables. |
| | 5 Wall elements or floor slabs. |

NOTE:

Maximum size of opening – Walls and floors 1.44m² (non-loadbearing).

Maximum size when reinforced for load bearing applications, please contact Promat Technical Services Department. Larger openings and load bearing capabilities can also be protected.

Please consult Promat Technical Services Department for support details.



Promat PROMASEAL® Fire Compound

Certifire Approval No CF 425

Promat PROMASEAL® Fire Compound - Approval Matrix

Penetrating Services				Fire Rating (min)		
	Maximum Aperture Dimension (mm)	Minimum Seal Depth (mm)		Integrity (mins)	Insulation (mins)	
		Loadbearing	Non-loadbearing			
Walls or floors	No service	1200	100	75	120	120
		1200	150	100	240	240
	Cables or Trunking or Dampers or Pipes ** (<60mm dia)	1200	100	75	120	0
		1200	150	100	240	0
Maximum Opening Area:		1.44m ² with a maximum service loading of 25% within each penetration seal				
Wall Thickness:		The floors and walls shall be a minimum of 100mm thick. The minimum density for the concrete of the floor or wall is 780kg/m ³ and for walls made of concrete blocks is 600kg/m ³ .				
Application Technique:		<p>Floors: Temporary or permanent shuttering will be required. In all instances where the span of the Promat PROMASEAL® Fire Compound exceeds 600mm, additional reinforcement e.g. re-bars will be necessary. For the floor seals fitted with reinforcement, the bars shall be 12mm diameter at 150mm centres. They shall be positioned at midthickness and supported at their ends on steel angles, typically 30mm x 30mm x 1.2mm thick, which are fastened to the concrete floor with all steel expanding anchors, at maximum 500mm centres.</p> <p>Walls: Promat PROMASEAL® Fire Compound should be progressively built up in order to avoid slumping. Usually a single shuttering board is used.</p>				
Service Support Requirements:		In all cases the services shall be supported adjacent to either face of the penetration seal at maximum 500mm.				

NOTE:

** Plastic pipes must be fitted with suitable fire protective collars or wraps.

The concrete floors and/or masonry or concrete walls shall be at least as thick as the sealing system as shown in the Approval matrix and have at least the same fire rating as that required for the penetration seal.

The services which may be fitted through the seals are electrical cables of various sizes from communication cables to power cables. The cables may be mounted in steel trunking or conduits. If fitted in trunking, the inside of the trunking around the cables must be filled with Promat PROMASEAL® Fire Compound where it passes through the seal.

Other services which may be fitted through the seals are steel, copper or plastic pipes.

Plastic pipes must be fitted with intumescent closing devices, or similar, which have been shown by certification in the required orientation to be suitable for use with this type of penetration sealing



Promat Fire Protection

Suite 1805, 18th Floor, Dubai Festival City Tower, P. O. Box 123945, Dubai, United Arab Emirates
Tel: +971 (4) 232 9780 Fax: +971 (4) 232 9781
www.promatfp.ae

an **Etex** GROUP company

HEALTH AND SAFETY

A safety data sheet is available from the Promat Technical Services Department and, as with any other materials, should be read before working with the product. The product is not classified as a dangerous substance and so no special provisions are required regarding the carriage and disposal of the product to landfill. This can be placed in an on-site skip with other general building waste which should be disposed of by a registered contractor.