

Promat PROMASEAL® Fire Barrier

Certifire Approval No CF 426



PRODUCT DESCRIPTION

Promat PROMASEAL® Fire Barriers are slabs of high density rock wool with a white endothermic, ablative coating.

APPLICATION

Promat PROMASEAL® Fire Barriers are used to stop the spread of fire through openings in fire resistant walls and floors where these are used for the passage of building and communications services. Acoustic data is available on this product, please contact the Technical Services Department on +971 (4) 232 9780.

FIRE PERFORMANCE

Promat PROMASEAL® Fire Barriers have been shown to provide a resistance to fire of 240 minutes when tested in accordance with the principles of BS 476: Part 20: 1987.

60 minute Promat PROMASEAL® Fire Barriers (walls only)

120 minute Promat PROMASEAL® Fire Barriers (walls and floors)

240 minute Promat PROMASEAL® Fire Barriers (walls only)

Please refer to tables 1, 2, 3 and 4 for specific details of periods of fire resistance (integrity and insulation).

ADVANTAGES

- Tested up to 240 minutes (walls) and 120 minutes (floors)
- Easily installed
- Allows fitting of additional services after installation
- Lightweight
- Easily cut to size
- Low smoke emission

INSTALLATION

Promat PROMASEAL® Fire Barriers are designed to be installed within openings in masonry, concrete or stud partition walls. The Promat PROMASEAL® Fire Barrier is cut to size such that a firm friction fit is achieved. Using a trowel or pallet knife, apply a layer of Promat PROMASEAL® Fire Barrier Coating to the areas in contact with the opening and also 'battered' onto the edges of the batt.

Where Promat PROMASEAL® Fire Barrier batts are cut to accommodate passage of services through the batt, the batt should be cut tight-fit into the opening and tight-fit around the service penetrations.

Promat PROMASEAL® Fire Barrier Coating must be used to point-in any service penetrations through the batt.

Services should be supported no more than 500mm from both sides of the PROMASEAL® Fire Barrier. Cables and services do not need coat back.

QUALITY ASSURANCE

Promat manufactures to a quality system in accordance with ISO 9001: 2008 and has received full accreditation to these standards.

Operating to these standards means that all activities, which have a bearing upon quality, are set out in written procedures. Systematic and thorough checks are made on all materials and their usage. Test equipment is subjected to regular checks and is referred back to national standards.

The information given in this data sheet is based on actual tests and is believed to be typical of the product. No guarantee of results is implied however, since conditions of use are beyond our control.

Promat PROMASEAL® Fire Barrier

TECHNICAL DATA

120 minutes fire rating, integrity in accordance with the criteria of BS 476: Part 20: 1987.

- 1 Promat PROMASEAL® Fire Barrier Coating, nominal 2mm thick.
- 2 Promat PROMASEAL® Fire Barrier (non-loadbearing) 50mm thick.
- 3 Cable trays.
- 4 Suspension or support of cable trays.
- 5 Cables, cable bunches, optical waveguides, metal pipes or service trunking.
- 6 Brickwork or concrete walls, with fire resistance to the same or greater than the fire resistance of the installed PROMASEAL® Fire Barrier system.
- 7 Light weight partitions, with fire resistance to the same or greater than the fire resistance of the installed PROMASEAL® Fire Barrier system.

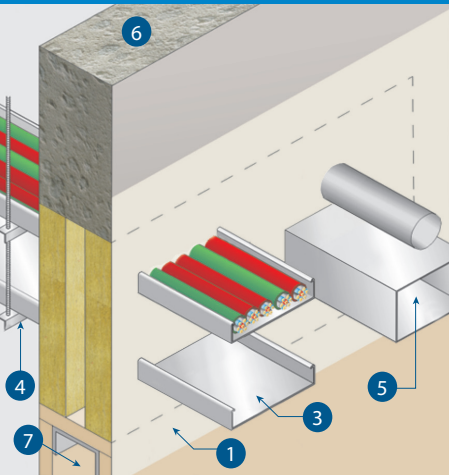

Detail 1

Detail 1 Solid Wall – Promat PROMASEAL® Fire Barrier System may be mounted in brickwork, concrete or lightweight walls to a minimum 130mm thick, provided the fire resistance is higher or equal to the installed system. For installations in thicker walls, Promat PROMASEAL® Fire Barrier can be arranged as a flush surface on both sides with a suitable gap in between. For cable seals, the cable trays have to be supported on both sides 500mm before the wall opening (4).

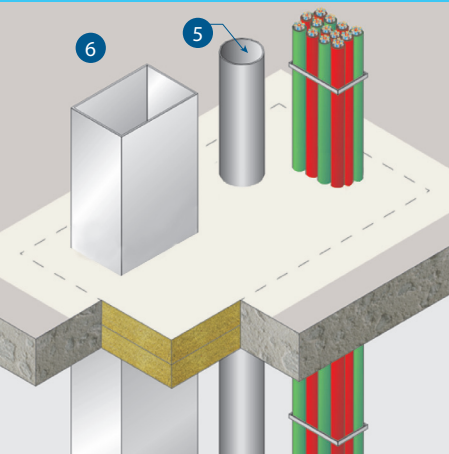

Detail 2

Detail 2 Lightweight Partition – The lightweight partitions should be tested to BS 476: Part 22: 1987 to the same or greater period of fire resistance as the Fire Barrier System.

Detail 3 Floor Penetration – Typical arrangement of cable trays within Promat PROMASEAL® Fire Barrier System.



Promat PROMASEAL® Fire Barrier

Certifire Approval No CF 426

Table 1 Approval Matrix - Up To 60 Minute Walls

Barrier	Service	Integrity	Insulation
Single layer (50mm)	Cable Ladder (340mm wide by 100mm high max.)	60 minutes	60 minutes
	Cables up to 26mm diameter	60 minutes	N/A
	Steel pipes up to 60mm diameter	60 minutes	30 minutes
	PVC pipes up to 110mm diameter*	60 minutes	N/A
	Steel ducts (445 mm wide by 445mm high max.)	60 minutes	N/A

* PVC pipes must be used in conjunction with Promat PROMASEAL® Pipe wraps over sealed with Promat PROMASEAL® Fire Barrier coating.

Maximum Aperture:	2880mm high by 2400mm/2400mm high by 2880mm wide (maximum area 6.91m ²). Multiple apertures must be separated by a minimum of 400mm in drywalls and 240mm in concrete/masonry constructions.
Walls:	The walls shall be a minimum of 66mm thick. The minimum density for the concrete or brick of the wall is 780kg/m ³ and for walls made of concrete blocks is 600kg/m ³ . Partition drywalls will comprise at least 1 layer of minimum 12.5 thick Type 'F' gypsum board on each side of minimum 70mm by 32mm steel studs. Promat SUPALUX® steel stud drywalls as specified in Certifire Approval CF420A will comprise at least 1 layer of minimum 9mm thick Promat SUPALUX® board on each side of minimum 48mm by 35mm steel studs. For further details of this construction CF420A should be consulted. All concrete, masonry or drywalls shall have at least the same fire rating as that required for the barrier.
Application Technique:	Concrete/Masonry walls: Batts tightly friction fitted into the aperture at mid-depth of the wall. Batt joints and the batt to aperture junction is sealed with Promat PROMASEAL® Fire Barrier Coating. Apertures for penetrating items are to be tightly fitting and be sealed with Promat PROMASEAL® Fire Barrier Coating and must be separated by at least 400mm. Gypsum Drywalls: As above and additionally the aperture must be formed from track sections and be lined with two layers of 12.5mm thick Type 'F' gypsum boards. Promat SUPALUX® Drywalls: As above and apertures must be formed from track sections and be lined with a layer of minimum 9mm thick Promat SUPALUX® board.
Service Coat-Back:	Not required.
Service Support Requirements:	Services should be rigidly supported via steel angles, hangers or channels, not further than 500mm from the surface of the sealing system on both faces.

Promat PROMASEAL® Fire Barrier

Certifire Approval No CF 426

Table 2 Approval Matrix - Up To 120 Minute Walls

Barrier	Service	Integrity	Insulation
Single layer (50mm)	Cable Ladder (340mm wide by 100mm high max.)	120 minutes	60 minutes
	Cables up to 26mm diameter	120 minutes	N/A
	Steel pipes up to 60mm diameter	120 minutes	30 minutes
	PVC pipes up to 110mm diameter*	120 minutes	N/A
	Steel ducts (445 mm wide by 445mm high max.)	120 minutes	N/A
Double layer (100mm) 2 x 50mm	Cable Ladder (340mm wide by 100mm high max.)	120 minutes	60 minutes
	Cables up to 26mm diameter	120 minutes	60 minutes
	Steel pipes up to 60mm diameter	120 minutes	30 minutes
	PVC pipes up to 110mm diameter*	60 minutes	N/A
	Steel ducts (445 mm wide by 445mm high max.)	120 minutes	N/A

* PVC pipes must be used in conjunction with Promat PROMASEAL® Pipe wraps over sealed with Promat PROMASEAL® Fire Barrier coating.

Maximum Aperture:	2400mm high by 1200mm (120 minutes integrity performance) 2880mm high by 1440mm (60 minutes integrity performance) Multiple apertures must be separated by a minimum of 400mm in drywalls and 240mm in concrete/masonry constructions.
Walls:	Multiple apertures must be separated by a minimum of 400mm in drywalls and 240mm in concrete/masonry constructions. The walls shall be a minimum of 130mm thick. The minimum density for the concrete or brick of the wall is 780kg/m ³ and for walls made of concrete blocks is 600kg/m ³ . Partition drywalls will comprise at least 2 layers of 15mm thick Type 'F' gypsum boards on each side of minimum 70mm by 32mm steel studs. All concrete, masonry or drywalls shall have at least the same fire rating as that required for the barrier.
Application Technique:	Concrete/Masonry walls: Batts tightly friction fitted into the aperture at mid-depth of the wall. Batt joints and the batts to aperture junction is sealed with Promat PROMASEAL® Fire Barrier Coating. Apertures for penetrating items are to be tightly fitting and be sealed with Promat PROMASEAL® Fire Barrier Coating and must be separated by at least 400mm. Dry walls: As above and additionally the aperture must be formed from track sections and be lined with two layers of 15mm thick Type 'F' gypsum board.
Service Coat-Back:	Not required.
Service Support Requirements:	Services should be rigidly supported via steel angles, hangers or channels, not further than 500mm from the surface of the sealing system on both faces.



Promat PROMASEAL® Fire Barrier

Certifire Approval No CF 426

Table 3 Approval Matrix - Up To 240 Minute Walls

Barrier	Service	Integrity	Insulation
Single layer (50mm)	Cable Ladder (340mm wide by 100mm high max.)	240 minutes	N/A
	Cables up to 26mm diameter	240 minutes	N/A
Double Layer 2 x 50mm (100mm)	Cable Ladder (340mm wide by 100mm high max.)	240 minutes	60 minutes
	Cables up to 20mm diameter	240 minutes	60 minutes
Maximum Aperture:	1000mm high and 660 mm wide subject to a maximum area of 0.6m ² . Multiple apertures must be separated by a minimum of 240mm in concrete/masonry constructions.		
Walls:	The walls shall be a minimum of 140mm thick. The minimum density for the concrete or brick of the wall is 780kg/m ³ and for walls made of concrete blocks is 600kg/m ³ . All concrete or masonry walls shall have at least the same fire rating as that required for the barrier.		
Application Technique:	Concrete/Masonry walls: Batts tightly friction fitted into the aperture at mid-depth of the wall. Batt joints and the batts to aperture junction is sealed with PROMASEAL® Fire Barrier Coating. Apertures for penetrating items are to be tightly fitting and be sealed with Promat PROMASEAL® Fire Barrier Coating and must be separated by at least 240mm.		
Service Coat-Back:	Not required.		
Service Support Requirements:	Services should be rigidly supported via steel angles, hangers or channels, not further than 500mm from the surface of the sealing system on both faces.		

Table 4 Approval Matrix - Up To 120 Minute Floors

Barrier	Service	Integrity	Insulation
Double Layer (100mm)	Cable Ladder (340mm wide by 100mm high max.)	120 minutes	60 minutes
	Cables up to 20mm diameter	120 minutes	60 minutes
Maximum Aperture:	1200mm long and 600mm wide subject to a maximum area of 0.72m ² . Multiple apertures must be separated by a minimum of 240mm in concrete constructions.		
Floors:	The floors shall be a minimum of 115mm thick. The minimum density for the concrete floor is 780kg/m ³ . All concrete floors shall have at least the same fire rating as that required for the barrier.		
Application Technique:	Concrete floors: Boards cut to size (not jointed) and tightly friction fitted into the aperture at mid-depth of the wall. Board to aperture junction is sealed with PROMASEAL® Fire Barrier Coating. Apertures for penetrating items are to be tightly fitting and be sealed with PROMASEAL® Fire Barrier Coating and must be separated by at least 240mm.		
Service Coat-Back:	Not required.		
Service Support Requirements:	Services should be rigidly supported via steel angles, hangers or channels, not further than 500mm from the surface of the sealing system on both faces.		



Promat Fire Protection

Suite 1805, 18th Floor, Dubai Festival City Tower, P. O. Box 123945, Dubai, United Arab Emirates
Tel: +971 (4) 232 9780 Fax: +971 (4) 232 9781
www.promatfp.ae

HEALTH AND SAFETY

A safety data sheet is available from the Promat Technical Services Department and, as with any other materials, should be read before working with the product. The product is not classified as a dangerous substance and so no special provisions are required regarding the carriage and disposal of the product to landfill. This can be placed in an on-site skip with other general building waste which should be disposed of by a registered contractor.

an **Etex** GROUP company